

Installation Note

**Agilent Technologies
E4407B, E4408B Spectrum Analyzers and
E7405A EMC Analyzers
APC 3.5 mm Input Connector (Option BAB)
Retrofit Kit**



Agilent Technologies

Part Number E4407-90041 Supersedes: E4407-90032
Printed in USA July 2005



E4407-90041

Notice.

The information contained in this document is subject to change without notice.

Agilent Technologies makes no warranty of any kind with regard to this material, including but not limited to, the implied warranties of merchantability and fitness for a particular purpose. Agilent Technologies shall not be liable for errors contained herein or for incidental or consequential damages in connection with the furnishing, performance, or use of this material.

Introduction

This procedure can be used to retrofit the APC 3.5 mm input connector (Option BAB) in E4407B, E4408B spectrum analyzers, or E7405A EMC analyzers. One kit is provided for all model numbers.

Products Affected:	E4407B Spectrum Analyzer E4408B Spectrum Analyzer E7405A EMC Analyzer
Serial Numbers:	Any
Option:	BAB
To Be Performed By:	(X) Agilent Technologies Service Center (X) Personnel Qualified by Agilent () Customer
Estimated Installation Time:.....	2.0 Hours
Estimated Verification Time:	3.0 Hours
Additional Recommended Task:	Agilent recommends a full calibration be performed to verify instrument specifications

To ensure that this newly installed option is functioning properly, the procedure that follows includes the requirement of performing certain adjustments and performance verification tests. However, the completion of these tests does not guarantee that the instrument meets all advertised specifications.

Software is required to perform the required adjustments, and can be used to automate the performance verification testing. Information on how to obtain this software can be found at:
www.agilent.com/find/calibrationsoftware

While Agilent does recommend that a full calibration be performed after the installation of this upgrade, the end user must ultimately determine whether they want this service or not. If a full calibration is required, arrangements regarding the level of calibration must be made between the end user and the calibration provider.

Installation Kit Parts List

Quantity	Description	Item Number
1	APC 3.5 connector assembly (A8J1)	E4407-60002
1	Cable assembly, RF IN/ATTN (W6)	E4404-20017
1	Adapter, APC 3.5 (f) to APC 3.5 (f)	5061-5311
1	Adapter, BNC (f) to SMA (m)	1250-1200
1	Option Upgrade Entitlement Certificate	---
1	APC 3.5 connector installation note	E4407-90001

Tools Required

- T-10 TORX screwdriver
- T-15 TORX screwdriver
- Function generator
- Synthesized sweeper
- Digital voltmeter
- Power meter, dual channel
- RF Power sensor (2 required)
- Microwave power sensor
- 50 Ohm termination
- Power splitter
- 20 dB Attenuator (Option 1DS only)
- APC 3.5 (m) Cable
- APC 3.5 (m) to Type-N (m) Adapter
- APC 3.5 (m) to Type-N (f) Adapter
- BNC Tee (f,m,f)
- Dual banana to BNC (f) Adapter

Torque Settings

To avoid potential RFI leakage and prevent connector damage, tighten to the following torque limits:

Item	Torque	
	In-lb	N-cm
SMA Connectors	8.5	95
3-mm, T-10 TORX screws	9	102
4-mm, T-15 TORX screws	21	236

WARNING Before you disassemble the instrument, turn the power switch to Standby and unplug the instrument. Failure to unplug the instrument can result in personal injury.

CAUTION Electrostatic discharge (ESD) can damage or destroy electronic components. All work on electronic assemblies should be performed at a static-safe workstation. Refer to the documentation that pertains to your instrument for information about static-safe workstations and ordering static-safe accessories.

Procedure

Removing the Dress Cover

1. Referring to [Figure 1](#), disconnect the analyzer from ac power (1).
2. Remove any adapters or cables connected to the front panel (2).
3. Position the handle (4) to the rear of the analyzer.
4. Carefully place the analyzer on the work surface with the front frame (3) facing down.
5. Remove the four screws (5) that hold the rear frame (6) and dress cover (7) in place.
6. Remove the rear frame (6) and dress cover (7) by sliding them towards the rear of the analyzer.

Figure 1 Dress Cover and Rear Frame Removal and Installation

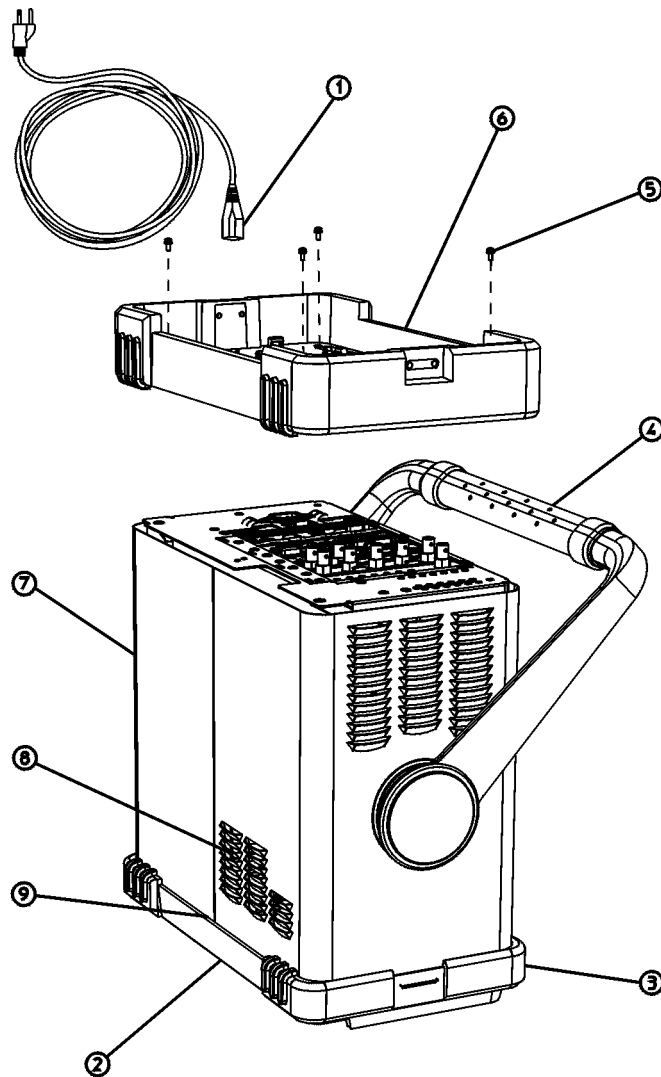

st745b

Extending the Front Frame

The front frame assembly can be extended from the instrument without detaching any connections or removing the chassis cover.

1. Referring to [Figure 2](#), with the instrument still on its face, remove the five screws (1), two on the bottom side and three on the top of the instrument, that secure the front frame to the RF assembly and chassis cover.
2. Place the instrument with the top side facing up and remove the remaining two screws (2) that secure the front frame subpanel to the chassis.
3. Slide the front frame forward until it catches on the tabs on the sides of the chassis.

Removing the Front Frame

Figure 2 Front Frame Assembly Removal

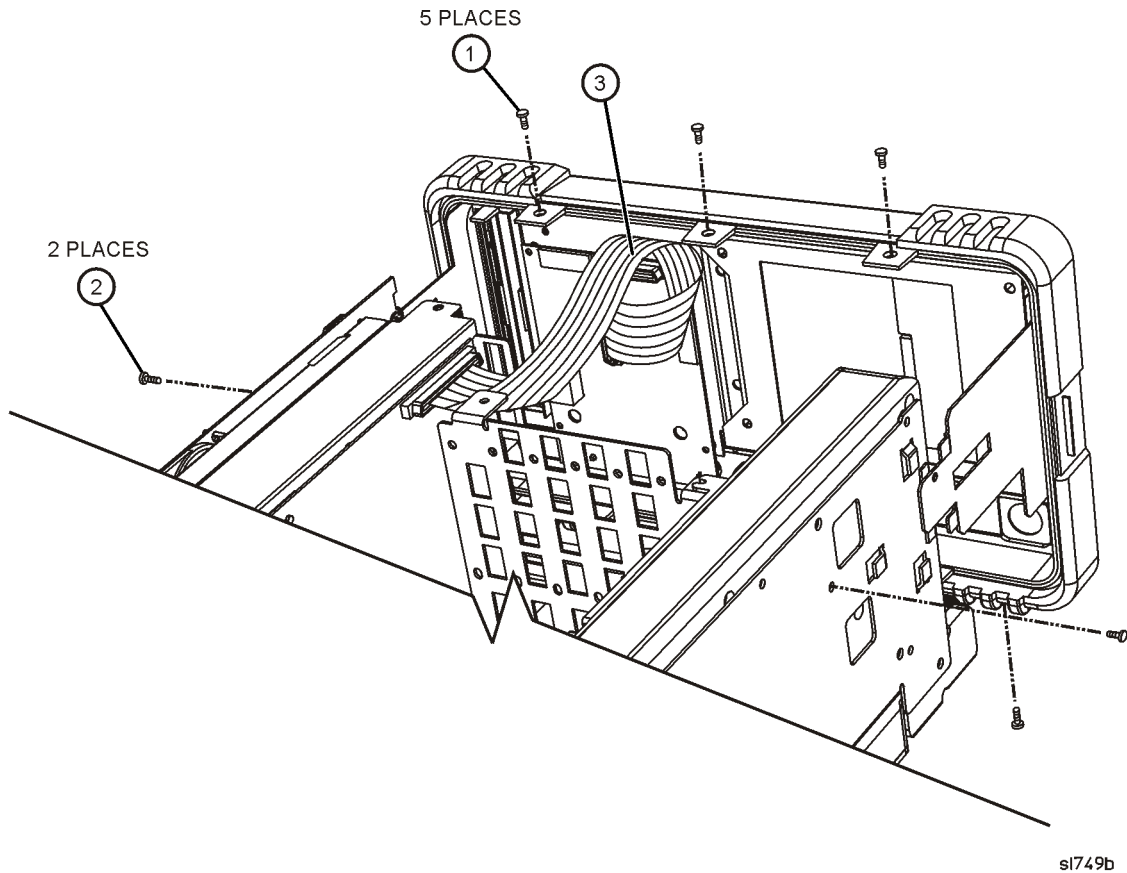

1. Disconnect the ribbon cable (3) from the front panel interface board.
2. Carefully pull the sides of the front frame subpanel away from the chassis and over the tabs on the chassis.
3. Slide the front frame forward to disengage from the chassis assembly.

Removing and Replacing the RF Input connector

1. Rotate the analyzer so the right side is resting on the table.
2. Referring to [Figure 3](#), locate W6 (1). W6 is a semi-rigid coax cable connected between the A8A5 input attenuator (2) and the A8J1 input connector (3).

Figure 3 Replacing the Input Connector and Cable

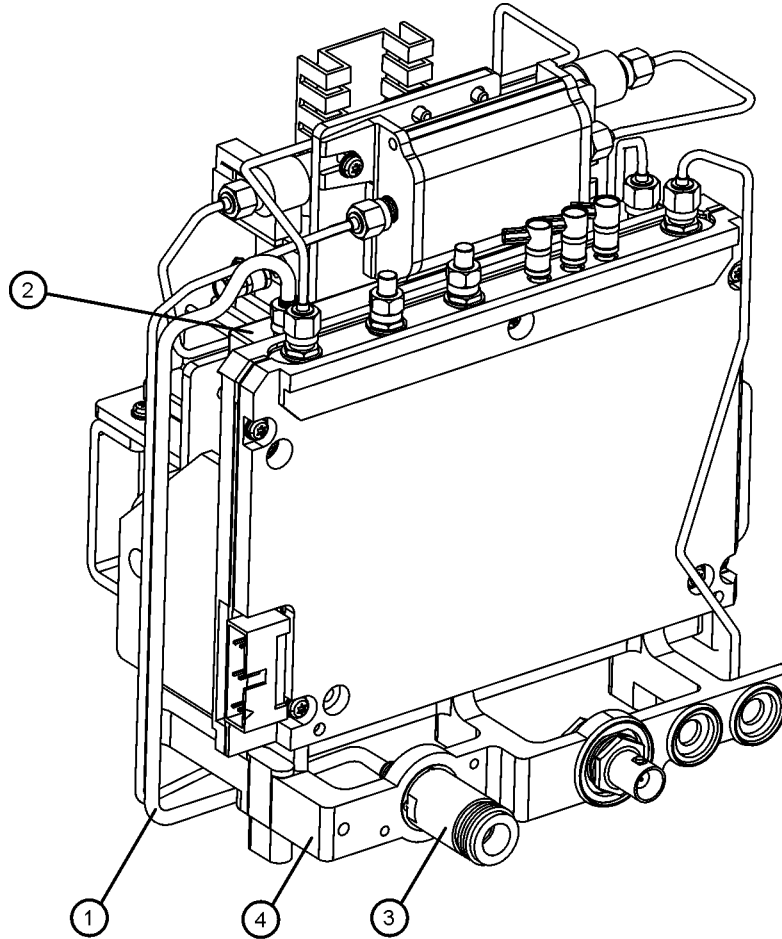

sl711bb

3. Remove W6 (1) from A8J1 (3), then from A8A5 (2). Discard the removed cable as it will no longer be needed.
4. Remove the A8J1 input connector from the midweb (4).
5. Attach the APC 3.5 mm input connector included in this kit to the midweb (4) using the two 3.0 mm screws provided in the connector kit.
6. Connect the new W6 semi-rigid cable, included in the kit, between the A8A5 input attenuator (2) and the APC 3.5 mm input connector (3). Tighten the SMA connectors to 8.5 inch pounds.

Replacing the Front Frame

1. Align the front frame subpanel rails with the chassis as shown in [Figure 2](#).
2. Referring to [Figure 2](#), connect the ribbon cable (3) to the front frame assembly.
3. Carefully slide the front frame toward the chassis, assuring the ribbon cable is not pinched between assemblies, and the RF input connector lines up correctly with the opening in the front frame.

NOTE Make sure the water seal is still in place around the input connector (and around the A2 tracking generator connector if the instrument is an Option 1DN) before reinstalling the front frame assembly.

4. Referring to [Figure 2](#), replace the five screws (1), and the two screws (2) that secure the front frame to the chassis. Tighten them to 9 inch-pounds.

Replacing the Dress Cover

1. Referring to [Figure 1](#), place the spectrum analyzer on the work surface with the front frame (3) facing down.
2. Replace the instrument outer case and rear frame assembly (6), matching the grill (8) on the bottom of the case to the bottom of the analyzer.
3. Fit the leading edge of the case completely into the slot (9) on the back of the front frame assembly.
4. Replace the four screws (5) to fasten the rear frame to the instrument. Tighten them to 21 inch-pounds.

Firmware Revision Verification

1. Turn on the analyzer and wait for the power-on alignments to complete. Check that there are no error messages displayed.
2. Press **System, More, Show System**. Make a note of the firmware revision and see if Option B72, Expansion Memory, is listed on the display.
3. If the firmware revision is A.06.00 or later, the firmware does not need to be updated and you can skip steps 4 through 6.
4. If your firmware revision is prior to A.06.00, you must update your analyzer firmware before the license key can be activated.
5. If Option B72, Expansion Memory is installed, you should update the instrument firmware to the latest version using one of the following methods:
 - Download the instrument firmware via the world-wide web at http://www.agilent.com/find/esa_firmware. This entire process of updating firmware will take approximately 45 minutes.
Note: If you are upgrading an EMC analyzer, go to www.agilent.com/find/emc_firmware.
 - Receive the latest firmware update disk set by ordering upgrade Option UE2.
Note: Special instructions in the Agilent ordering configurator should have made you aware of Option UE2 in case access to the internet wasn't available.
6. If Option B72, Expansion Memory is not installed, you should update the instrument firmware to version A.07.06. This is the latest version for instruments that do not have Option B72 installed.
 - Download the instrument firmware via the world-wide web at http://www.agilent.com/find/esa_firmware_std-mem. This entire process of updating firmware will take approximately 45 minutes.
 - Order upgrade Option B72, which includes the expansion memory and the latest ESA firmware update disk set.

Obtaining a License Key and Activating the Option

The entitlement certificate supplied in this kit allows you to obtain a license key from our Agilent website so you can enable this upgrade option. Once you have retrieved the license key, you can begin the process of activating the option.

1. Press **System, More, More, Licensing, Option**. When you press **Option**, the alpha editor will be activated. For instructions on using the alpha editor, refer to the analyzer User's Guide.
2. Use the alpha editor to enter the three-character designation for the option, in this case, "BAB", that you want to activate.
3. Press **Enter** when done.
4. Press **License Key**. When you press **License Key** the alpha editor will be activated.
5. Use the alpha editor and the numeric keypad to enter the 12-character license key number (for example: D7C374DABD5B) for the option that you want to activate.
6. Press **Enter** when done.
7. Press **Activate** to turn on the option.
8. If the option and license key entries were correct, a message stating "Option Activated" will appear on the analyzer display.
9. Press **System, More, Show System** to verify existence of Option BAB.

Perform Adjustments and Performance Tests

Adjustments Required

The adjustments listed below are required following this upgrade installation. These adjustments can only be performed using the software outlined in the Introduction of this installation note. The adjustments must be performed in the order that they are listed below. They must also be done prior to running any performance verification testing.

- Frequency Response

Performance Testing Required

The performance tests listed below are the minimum recommended set that will verify the upgrade just installed is functioning correctly. Performing these tests alone does not guarantee that the instrument meets all advertised performance specifications. The performance test procedures can be found in the ESA Spectrum Analyzer Calibration Guide, or the tests can be performed using the software outlined in the Introduction of this installation note.

- Frequency Response
- Displayed Average Noise Level
- Residual Responses

NOTE **A full calibration is required to ensure the instrument meets all advertised performance specifications.**
